





**PROFILE**  
**20 x 20**



|                 |  |
|-----------------|--|
| Material        | Aluminium (6063-T5)                                  |
| Weight          | 0.445 kg/m   |
| Length          | 5000 mm  |
| Mass of Inertia | Ix 0.71 cm <sup>4</sup><br>Iy 0.71 cm <sup>4</sup>   |
| Section Modulus | Zx 0.071 cm <sup>3</sup><br>Zy 0.071 cm <sup>3</sup> |

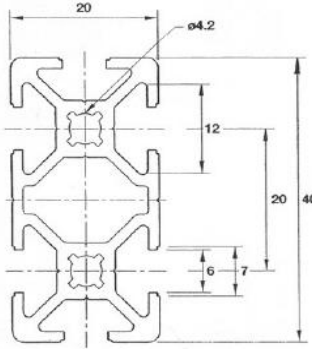



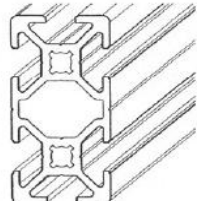

**PROFILE**  
**20 x 40**

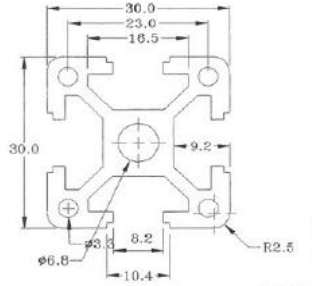
|                 |  |
|-----------------|--|
| Material        | Aluminium (6063-T5)                              |
| Weight          | 0.77 kg/m  |
| Length          | 5000 mm  |
| Mass of Inertia | Ix 4.5 cm <sup>4</sup><br>Iy 1.2 cm <sup>4</sup> |
| Section Modulus | Zx 2.2 cm <sup>3</sup><br>Zy 1.2 cm <sup>3</sup> |

**PROFILE**  
**30 x 30**

|                 |  |
|-----------------|--|
| Material        | Aluminium (6063-T5)                              |
| Weight          | 1.006 kg/m                                       |
| Length          | 5000 mm  |
| Mass of Inertia | Ix 3.3 cm <sup>4</sup><br>Iy 3.3 cm <sup>4</sup> |
| Section Modulus | Zx 2.2 cm <sup>3</sup><br>Zy 2.2 cm <sup>3</sup> |

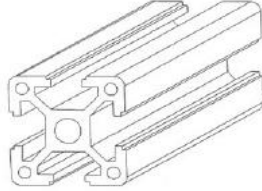
**HALF-ROUND PROFILE**  
**40 x 40CR**

|                 |  |
|-----------------|--|
| Material        | Aluminium (6063-T5)                              |
| Weight          | 1.5 kg/m   |
| Length          | 5000 mm  |
| Mass of Inertia | Ix 5.4 cm <sup>4</sup><br>Iy 5.4 cm <sup>4</sup> |
| Section Modulus | Zx 2.1 cm <sup>3</sup><br>Zy 2.1 cm <sup>3</sup> |

**PROFILE**  
**40 x 40**

|                 |  |
|-----------------|--|
| Material        | Aluminium (6063-T5)                              |
| Weight          | 1.459 kg/m                                       |
| Length          | 5000 mm  |
| Mass of Inertia | Ix 8.2 cm <sup>4</sup><br>Iy 8.2 cm <sup>4</sup> |
| Section Modulus | Zx 4.1 cm <sup>3</sup><br>Zy 4.1 cm <sup>3</sup> |

**PROFILE**  
**40 x 40**

|                 |  |
|-----------------|--|
| Material        | Aluminium (6063-T5)                              |
| Weight          | 1.861 kg/m                                       |
| Length          | 5000 mm  |
| Mass of Inertia | Ix 9.9 cm <sup>4</sup><br>Iy 9.9 cm <sup>4</sup> |
| Section Modulus | Zx 2.1 cm <sup>3</sup><br>Zy 2.1 cm <sup>3</sup> |

**PROFILE**

**40 x 80**

|                 |  |
|-----------------|--|
| Material        | Aluminium (6063-T5)                                |
| Weight          | 2.650 kg/m   |
| Length          | 5000 mm  |
| Mass of Inertia | Ix 61.2 cm <sup>4</sup><br>Iy 17.0 cm <sup>4</sup> |
| Section Modulus | Zx 15.3 cm <sup>3</sup><br>Zy 8.5 cm <sup>3</sup>  |

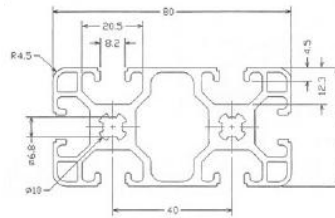
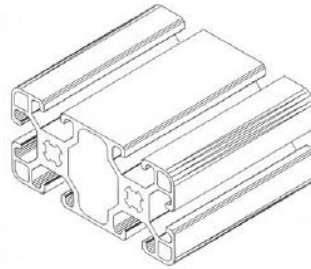

**PROFILE**

**40 x 80**

|                 |  |
|-----------------|--|
| Material        | Aluminium (6063-T5)                                |
| Weight          | 3.288 kg/m   |
| Length          | 5000 mm  |
| Mass of Inertia | Ix 73.7 cm <sup>4</sup><br>Iy 19.1 cm <sup>4</sup> |
| Section Modulus | Zx 18.4 cm <sup>3</sup><br>Zy 9.5 cm <sup>3</sup>  |

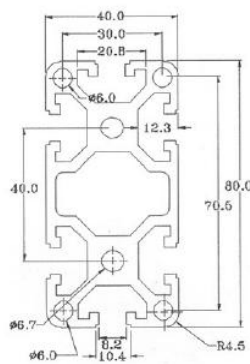
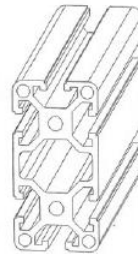

**PROFILE**

**80 x 80**

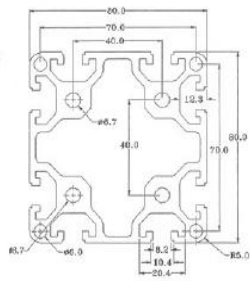
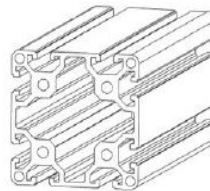

|                 |  |
|-----------------|--|
| Material        | Aluminium (6063-T5)                                  |
| Weight          | 5.351 kg/m   |
| Length          | 5000 mm  |
| Mass of Inertia | Ix 137.2 cm <sup>4</sup><br>Iy 137.2 cm <sup>4</sup> |
| Section Modulus | Zx 34.3 cm <sup>3</sup><br>Zy 34.3 cm <sup>3</sup>   |

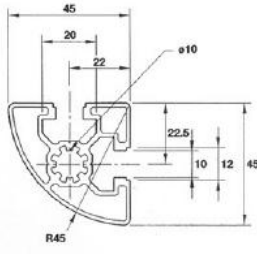



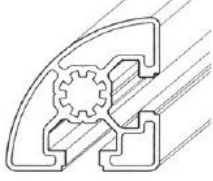

**PROFILE**  
**45 x 45**

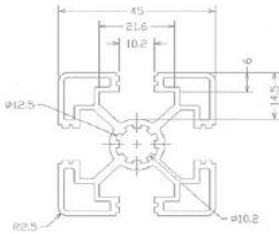
|                 |  |
|-----------------|--|
| Material        | Aluminum (6063-T5)                               |
| Weight          | 1.29 kg/m  |
| Length          | 5000 mm  |
| Mass of Inertia | Ix 7.6 cm <sup>4</sup><br>Iy 7.6 cm <sup>4</sup> |
| Section Modulus | Zx 3.4 cm <sup>3</sup><br>Zy 3.4 cm <sup>3</sup> |

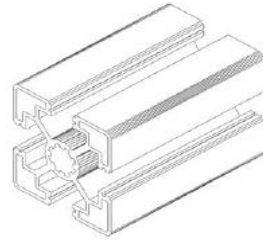

**PROFILE**  
**45 x 45L**

|                 |  |
|-----------------|--|
| Material        | Aluminum (6063-T5)                                 |
| Weight          | 1.521 kg/m   |
| Length          | 5000 mm  |
| Mass of Inertia | Ix 10.4 cm <sup>4</sup><br>Iy 10.4 cm <sup>4</sup> |
| Section Modulus | Zx 4.6 cm <sup>3</sup><br>Zy 4.6 cm <sup>3</sup>   |

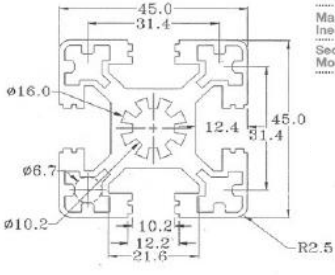
**PROFILE**  
**45 x 45**

|                 |  |
|-----------------|--|
| Material        | Aluminum (6063-T5)                                 |
| Weight          | 2.21 kg/m  |
| Length          | 5000 mm  |
| Mass of Inertia | Ix 14.3 cm <sup>4</sup><br>Iy 14.3 cm <sup>4</sup> |
| Section Modulus | Zx 6.3 cm <sup>3</sup><br>Zy 6.3 cm <sup>3</sup>   |

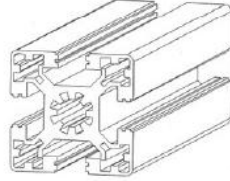

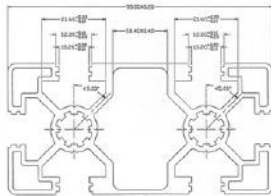
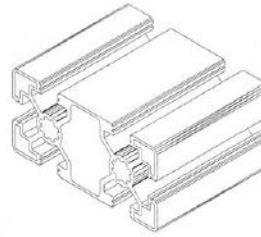

**PROFILE****45 x 90**

|                 |  |
|-----------------|--|
| Material        | Aluminium (6063-T5)                                |
| Weight          | 3,941 kg/m   |
| Length          | 5000 mm  |
| Mass of Inertia | Ix 47.7 cm <sup>4</sup><br>Iy 47.7 cm <sup>4</sup> |
| Section Modulus | Zx 15.9 cm <sup>3</sup><br>Zy 15.9 cm <sup>3</sup> |

**PROFILE****45 x 90**

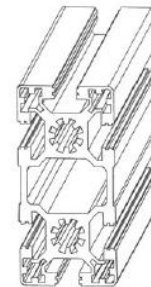
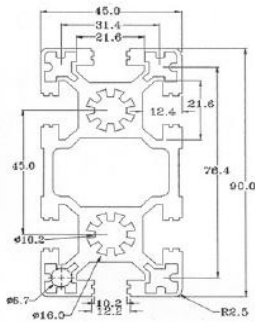
|                 |  |
|-----------------|--|
| Material        | Aluminium (6063-T5)                                |
| Weight          | 3,288 kg/m   |
| Length          | 5000 mm  |
| Mass of Inertia | Ix 73.7 cm <sup>4</sup><br>Iy 19.1 cm <sup>4</sup> |
| Section Modulus | Zx 18.4 cm <sup>3</sup><br>Zy 9.5 cm <sup>3</sup>  |

**PROFILE****45 x 60**

|                 |  |
|-----------------|--|
| Material        | Aluminium (6063-T5)                                |
| Weight          | 2,579 kg/m   |
| Length          | 5000 mm  |
| Mass of Inertia | Ix 16.6 cm <sup>4</sup><br>Iy 29.6 cm <sup>4</sup> |
| Section Modulus | Zx 7.3 cm <sup>3</sup><br>Zy 9.8 cm <sup>3</sup>   |

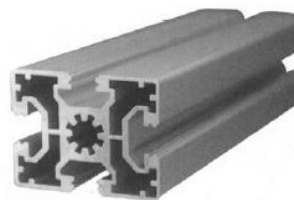
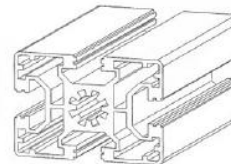
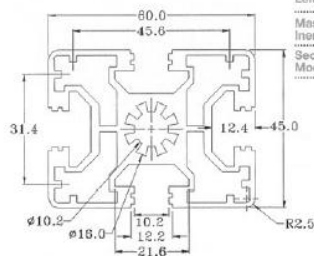

**PROFILE**  
**60 x 60**

|                 |  |
|-----------------|--|
| Material        | Aluminium (6063-T5)                                |
| Weight          | 3,941 kg/m   |
| Length          | 5000 mm  |
| Mass of Inertia | Ix 47.7 cm <sup>4</sup><br>Iy 47.7 cm <sup>4</sup> |
| Section Modulus | Zx 15.9 cm <sup>3</sup><br>Zy 15.9 cm <sup>3</sup> |

**PROFILE**  
**90 x 90**

|                 |  |
|-----------------|--|
| Material        | Aluminium (6063-T5)                                  |
| Weight          | 0,445 kg/m   |
| Length          | 5000 mm  |
| Mass of Inertia | Ix 0.71 cm <sup>4</sup><br>Iy 0.71 cm <sup>4</sup>   |
| Section Modulus | Zx 0.071 cm <sup>3</sup><br>Zy 0.071 cm <sup>3</sup> |

**PROFILE**  
**45 x 45**

|                 |  |
|-----------------|--|
| Material        | Aluminium (6063-T5)                              |
| Weight          | 1,008 kg/m                                       |
| Length          | 5000 mm  |
| Mass of Inertia | Ix 3.3 cm <sup>4</sup><br>Iy 3.3 cm <sup>4</sup> |
| Section Modulus | Zx 2.2 cm <sup>3</sup><br>Zy 2.2 cm <sup>3</sup> |